

Model SB & 33" Base Tube <b>\$590.00</b>	Model SB & 59" Base Tube <b>\$650.00</b>	Model SB & 85" Base Tube <b>\$710.00</b>
For Waterline @ 3' - 4' or less	For Waterline @ 5' - 6'	For Waterline @ 7' - 8'
		
33" Base Tube Ship Wt. 17 lbs.	59" Base Tube Ship Wt. 36 lbs.	85" Base Tube Ship Wt. 55 lbs.

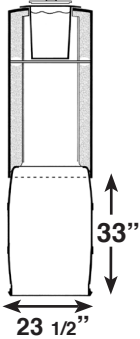
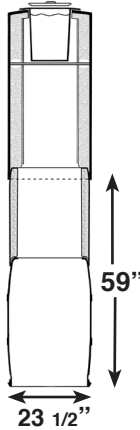
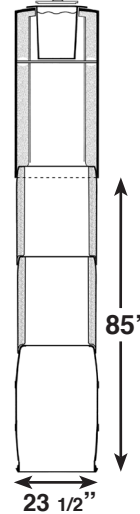
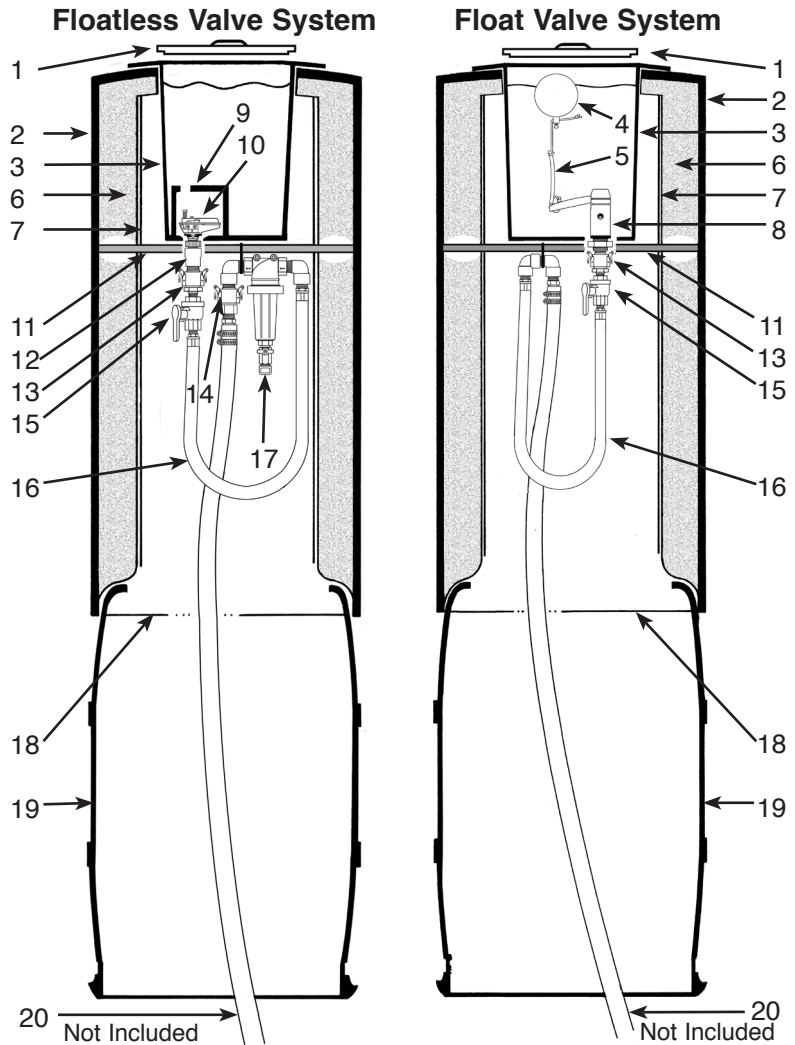

## Model SB Waterer:

- 24" D x 48" H
- Ship Wt. 64 lb.

**Gallons: 5**

**Opening: 11 1/2"**

**Side Reach: 6"**

**Water Level:**

- 2" - 3" from top of tub

**Drinking Height:**

- 20" Maximum or less

**Waterer, Tub & Float**

**Construction:**

- 1/4" Polyethylene Plastic

**Base Tube Construction:**

- 3/16" Polyethylene Plastic
- 33" Tube - no insulation
- 59" & 85" Tubes partially insulated - 2" thick

**Capacity:**

- Dry Lot Beef: 65 Head
- Range Cows: 35 Head

## 2 Valve Options

### 1/4" Floatless Valve

Pressure Feed  
Clean Water Only

1/4" Orifice

Ballcock Thread

Max: 100 PSI = 10 GPM

Avg: 40 PSI = 5 GPM

### 1/2" HD Valve

Pressure Feed

1/2" Orifice

Inside: 3/4" NPT

Outside: 1 3/8" Bolt Thd.

Max: 80 PSI = 18 GPM

Avg: 40 PSI = 10 GPM

-OR-

Gravity Feed - Pond

Capacity may be reduced!

1. Lid (extended nonuse)
2. Model SB Waterer
3. Tub
4. 5 3/8" Polyethylene Float
5. 3/16" Cord & 3/8" Sleeve
6. 3" Polyurethane Insulation
7. Foil Liner
8. Float Valve
9. Valve Guard
10. Floatless Valve
11. Support Rod

12. White Coupler
13. Quick Coupler & Adapter
14. Quick Coupler & Adapter
15. Ball Valve
16. Flexible Hose
17. Strainer & Flush Valve
18. Black Overlap Line
19. 33" Base Tube
20. 1" Polyethylene Waterline not included

## Included:

- A) 17" Valve Adjuster for floatless valve only
- B) 20" Ice Chipper
- C) 20" Tie Cord
- D) S.S. Hose Clamps

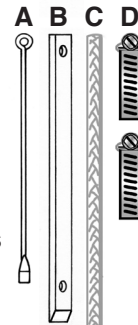

## OPTIONAL

**Filter Fabric**  
15' x 15'  
**\$30.00**

Factory prices are F.O.B. at East Peru, Iowa and subject to change without notice.

**Choose Model, Tube & Valve - CALL 1-888-699-4722**